

PC Card Single Slot SMT Connectors for the AV Market (that Support 5 V Cards)

IC15 Series

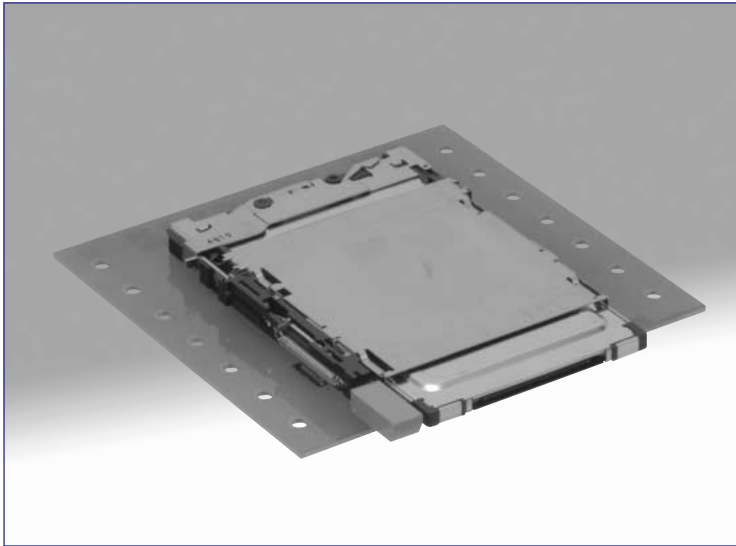

Reliable card ejection

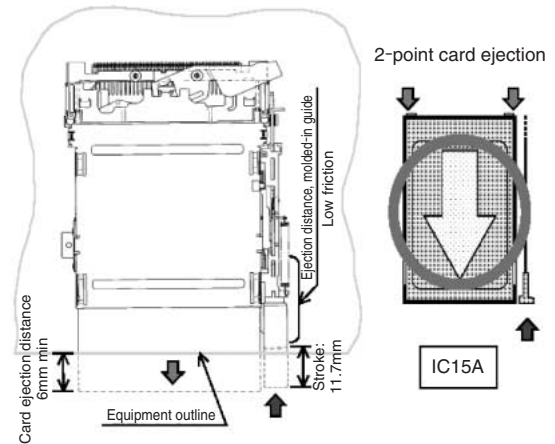

■ Features

1. Reliable card ejection

Designed for the front mounted Audio/Visual equipment the connectors eject the inserted card by applying force equally at each edge of the card (distance of 6 mm minimum), allowing easy hold of the card for the final removal.

2. New three-stage “Pop-Up” card ejection mechanism

The button does not protrude without the card being inserted, preventing it's damage when carrying the portable devices.

3. Secure board retention

Built-in 4 points of board retention posts assure that the card insertion shock is not transferred to the solder joints.

4. Supports lead-free environments

All components use lead-free materials.

Three-stage card ejection

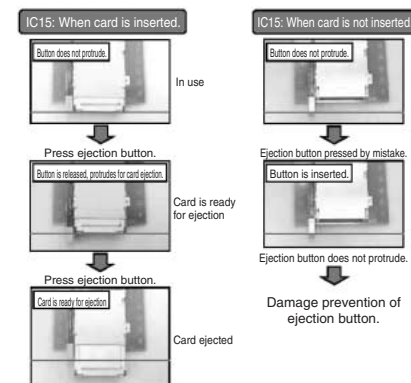

■ Applications

DVD recorders, LCD TVs, PDP and other digital AV equipment

■Product Specifications

Ratings	Current rating	0.5A	Operating temperature range	-55°C to +85°C (Note 1)	Storage temperature range	-40°C to +70°C (Note 1)
	Voltage rating	125V AC	Operating humidity range	Relative humidity 95% max. (No condensation)	Storage humidity range	40% to 70% (Note 1)

Item	Specifications	Conditions
1. Insulation resistance	100 MΩ min.	500 V DC
2. Withstanding voltage	No flashover or insulation breakdown.	500 V AC / one minute
3. Contact resistance	60 mΩ max. (Initial value)	1mA DC
4. Vibration	No electrical discontinuity of 100 ns or more.	Frequency: 10 to 2000 Hz, single amplitude of 1.52 mm or acceleration of 147m/s ² (peak), 4 hours / 3 axis
5. Humidity	Insulation resistance: 100 MΩ min.	96 hours at temperature of 40°C±2°C and humidity of 90% to 95%
6. Temperature cycle	Insulation resistance: 100 MΩ min.	Temperature: -55°C → +5°C to +35°C → +85°C → +5°C to +35°C Duration: 30 → 5 max. → 30 → 5 max. (Minutes) 5 cycles
7. Durability (mating/unmating)	Contact resistance: 20mΩ max. from initial value	10000 cycles at 400 to 600 cycles per hour
8. Resistance to soldering heat	No deformation of any component. No affect on contacts.	Reflow: At the recommended temperature profile Manual soldering: 300 °C for 3 seconds

Note 1: Includes temperature rise caused by current flow.

Note 2: The term "storage" refers to products stored for long period of time prior to mounting and use. Operating Temperature Range and Humidity range covers non- conducting condition of installed connectors in storage, shipment or during transportation.

■Materials/Finish

SMT unit

Component	Material	Finish	Remarks
Insulator	Heat resistant thermoplastic compound	Color: Black	UL94V-0
Contacts	Brass	Contact area: Gold plated Termination area: Tin plated	_____
Ground/eject metal fittings	Stainless steel	_____	_____
Positioning pin	Brass	Tin plated	_____

Guide unit

Component	Material	Finish	Remarks
Frame	PBT	Color: Black	UL94V-0
Cover/Metal components	Stainless	_____	_____
Spring	Stainless steel	_____	_____
Ejection button	ABS	Color: Gray	UL94V-HB

Note: Lead free products

■ Ordering information

● SMT unit

IC15 A - PDR - SF M - EJL
 ① ② ③ ④ ⑤ ⑥

① Series name: IC15	④ SF: Right angle surface mount
② Stand off height A: 2.2mm	⑤ M: With Vacuum pick-up plate
③ Terminal type PDR: Reverse type (5V type)	⑥ Ejection button type EJL: Left button eject

● Guide unit

IC15 A - G - P EJL
 ⑦ ⑧ ⑨ ⑩ ⑪

⑦ Series name: IC15	⑩ Eject mechanism codes P: Pop-up button
⑧ Stand off height A: 2.2mm	⑪ Ejection button type EJL: Left button eject
⑨ G: Guide unit	

Note: One SMT unit and one Guide unit constitute one assembly. They can not be ordered separate.

◆Method of Attachment to the Board and Precautions

(1) Exercise caution when handling the Guide unit.

If needed, re-position the push rod or the stroke arm as indicated in Fig.1

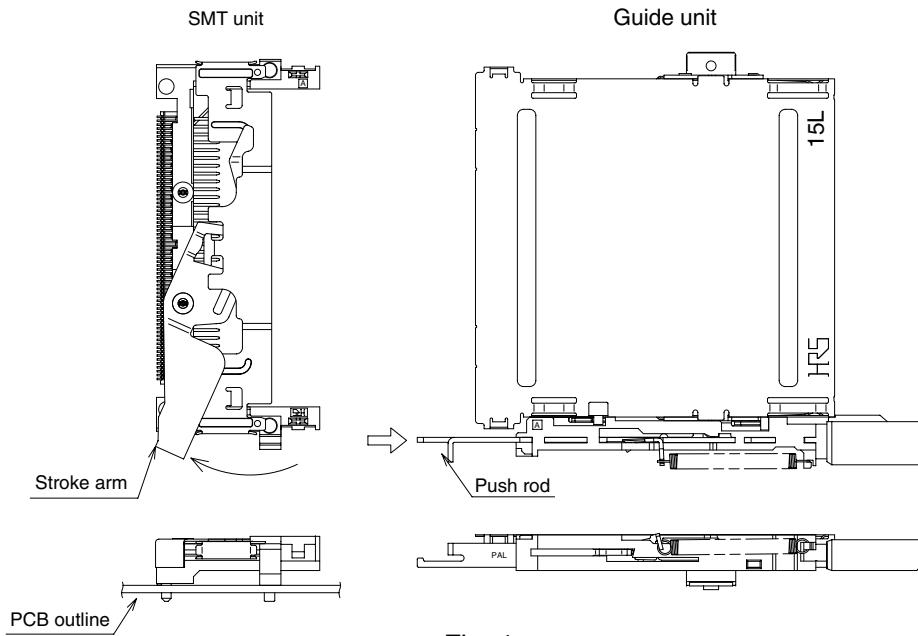

Fig. 1



Fig. 2

(2) Align the left and right locking tabs (Fig. 4) of the Guide unit shield plate with the left and right openings on the SMT unit insulator. (Fig. 3)

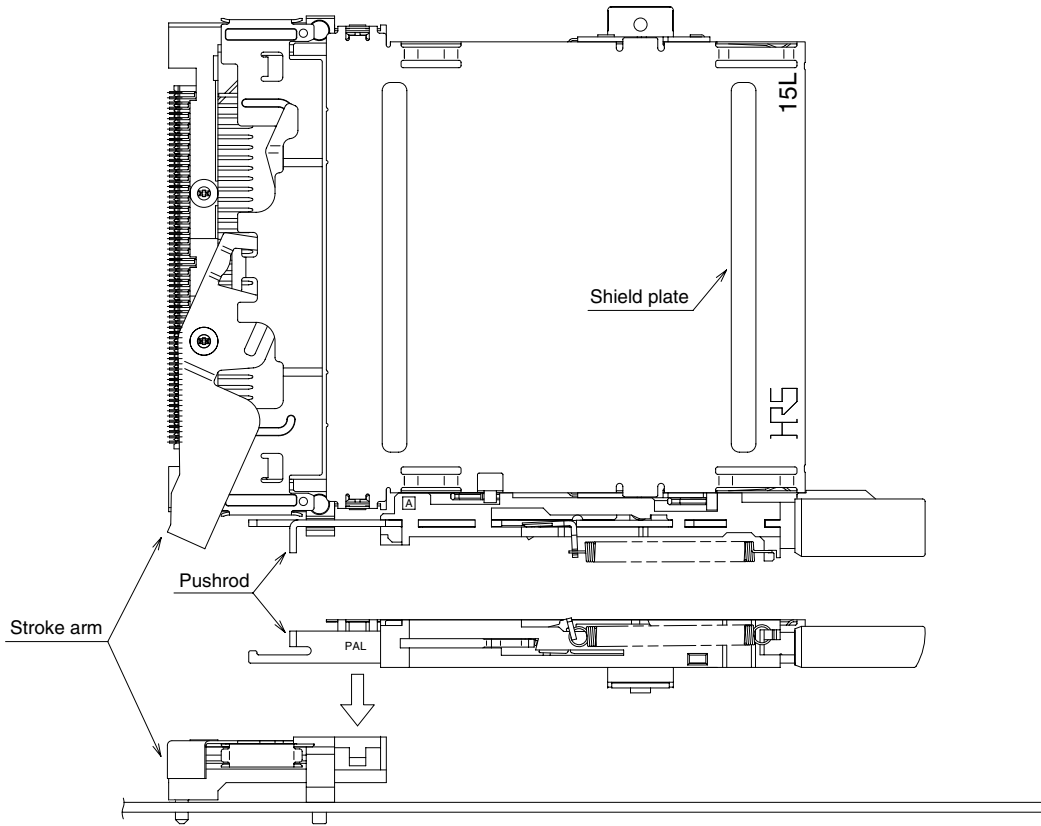

Fig. 3

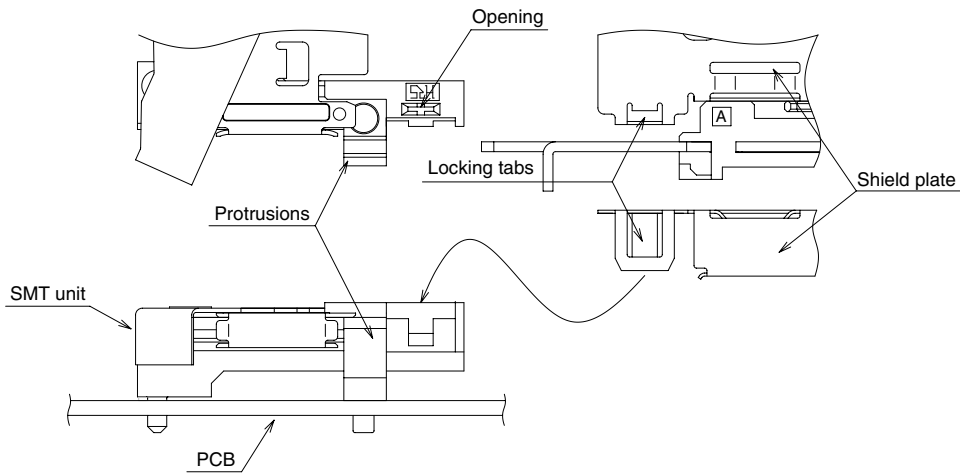
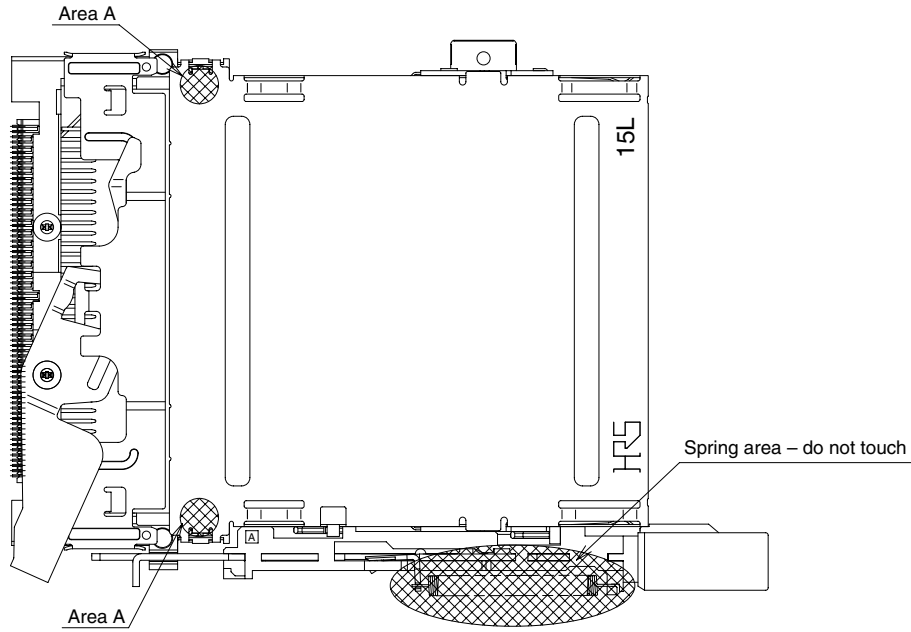

Fig. 4

(3) Assuring the correct alignment firmly press-down the shield plate of the Guide unit (at the areas “A”) into the SMT unit until a loud “click” sound is heard. Both units should be now firmly locked together.



Note 1: When placing the Guide unit over the SMT unit, DO NOT press on any other area than “A”.

(4) Attach the Guide unit in two places using recommended screws (Not supplied).

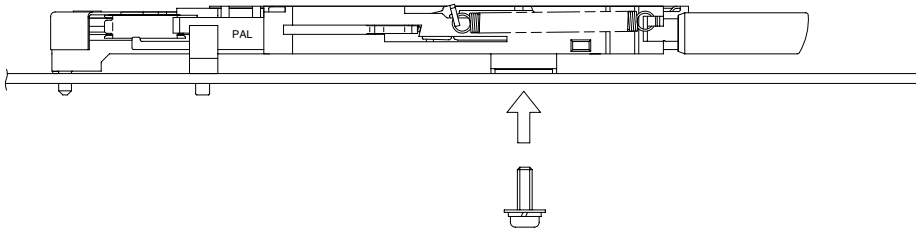

Screw description	Recommended Fastening Torque
M2×0.4	0.12~0.16 (N · m)

Note 2: When attaching the screws exercise caution not to deform the shield plate.

Note 3: Do not insert/eject the PC card before the SMT unit and the Guide unit are fully mounted and locked.

Note 4: Metal components of these connector assemblies have sharp edges. Use caution when handling and assembling.

Note 5: Slight tool marks or cleaning fluid residue on the surfaces of the Guide unit will not affect form, fit or function of the assemblies.

◆ Recommended temperature profile

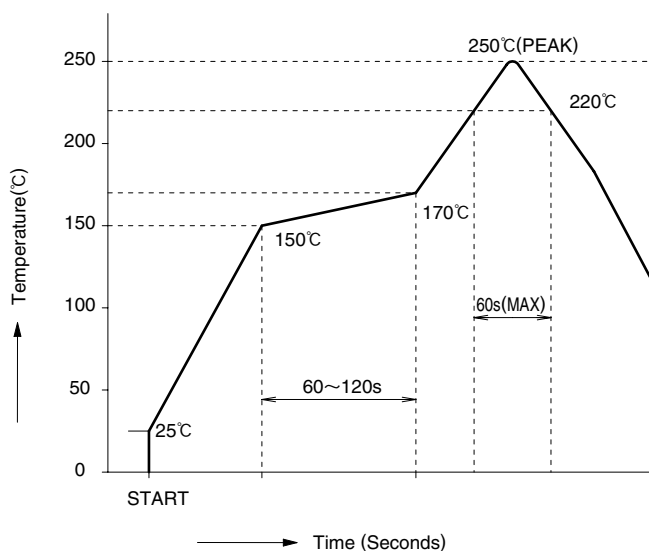

● Recommended conditions

- Reflow system: IR reflow
- Solder composition: Paste, 96.5%Sn/3.0%Ag/0.5%Cu (Flux content 10.5wt%)
- Test board: Glass epoxy 80mm×125mm×1.6mm thick
- Metal mask: 0.15mm thick

The temperature profiles are based on the above conditions.

In individual applications the actual temperature may vary, depending on solder paste type, volume/thickness and board size/thickness. Consult your solder paste and equipment manufacturer for specific recommendations.